

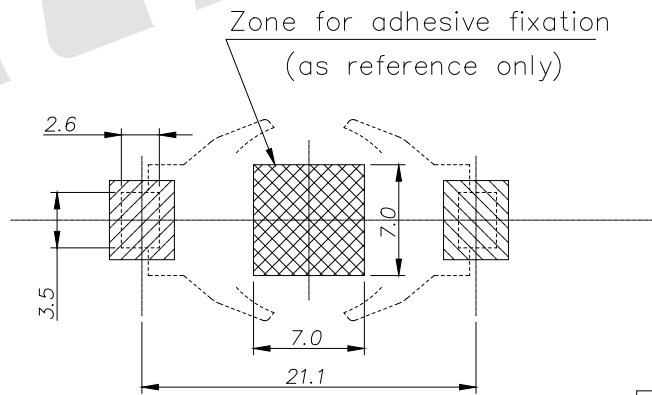

NOTES:

- 1. Housing: LCP E130i, UL94V-0 UL No: E106764 Colr: Nature
- 2. Contact: Spring Stainless Steel 301 First Grade, T=0.15mm High Temp Tin Plated 100-200U'' over Nickel 30u''
- 3. Working Temp: -40° C To +100° C

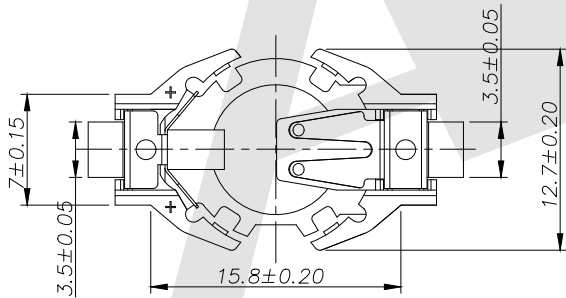
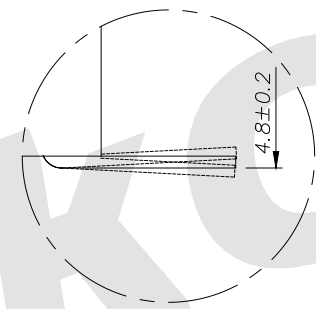
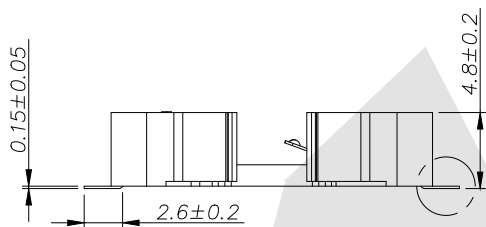
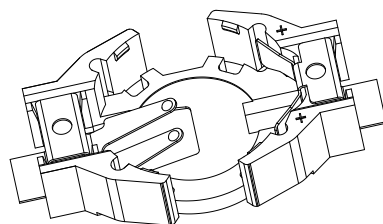
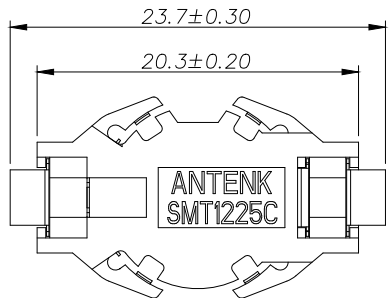

Order Code:

BT - M - SN - X - 1225C
 ① ② ③ ④ ⑤

- ① BT: Coin Cell Holders
- ② Apperance For The Product
M: SMT TYPE
S: 180 TYPE
R: 90 TYPE
- ③ Contact Plating
SN: Tin
G0: G01d flash G1: 3U'' Gold
G2: 5U'' Gold G3: 10U'' Gold
G4: 15U'' Gold G5: 30U'' Gold
- ④ Packing Method
A: Tray Packing
R: Tape & Reel Packing
- ⑤ Product Number
1225C

Unless Otherwise specified tolerance
 X. ±0.35 X.XX: ±0.20
 X.X: ±0.25 X.XXX: ±0.15

Atkconn® ATKCONN ELECTRONICS CO., LTD
[Http://www.atkconn.com](http://www.atkconn.com)

SCALE: As Shown UNIT: mm
 DRAW ZLA DATE 21/07/2022
 CHECK BobYang DATE 21/07/2022

TITLE:
Coin Cell Holders SMT For 1225C
 DRAWING NO: BS-M-SN-X-1225C
 PRODUCT NO: BS-M-SN-X-1225C

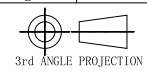

REV	DESCRIPTION	DATE
1		



ITEM	W	A0	B0	K0	K1	P	F	E	D	P0	P2	T	13"	
DIM	44.0	13.6	24.2	4.9	0.0	16	0.0	1.75	1.50	4.00	2.00	0.35	长度/盘	元件/盘
TOLE	+0.30 -0.30	+0.10 -0.10	+0.10 -0.10	+0.10 -0.10	+0.10 -0.10	+0.10 -0.10	+0.10 -0.10	+0.10 -0.10	+0.10 -0.00	+0.10 -0.10	+0.15 -0.15	+0.05 -0.05	M	750pcs

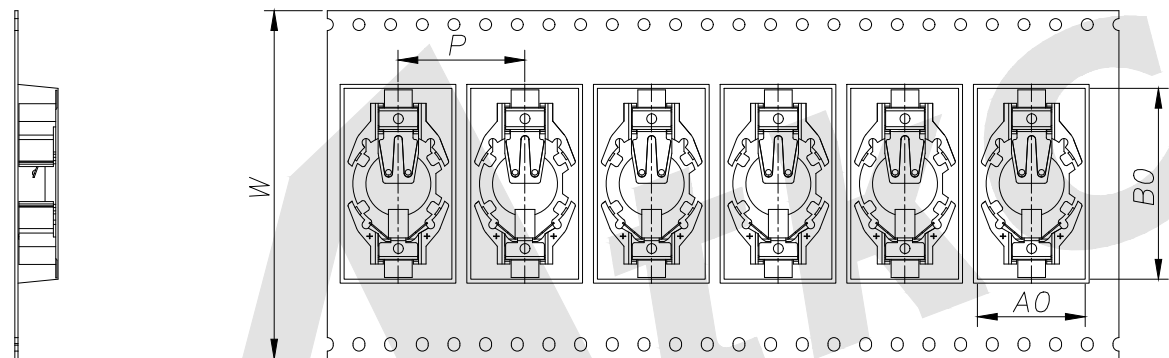
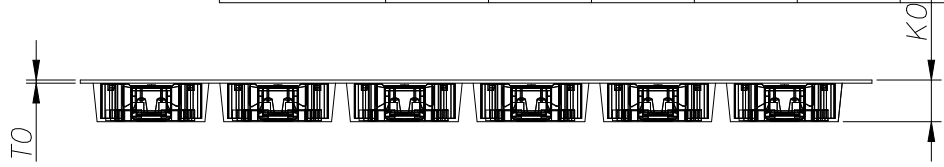

REMARK:

- (1) The cumulative error of any 10 ratchet holes shall not exceed + / -0.20mm;
- (2) The thickness of the material shall be measured at the edge of the belt;
- (3) The non parallelism of 100 mm distance in the direction of belt length shall not exceed 1 mm;
If it exceeds 250mm, the accumulated error will not be calculated;
- (4) The tolerance range not specified is + / - 0.1mm;
- (5) A0 and B0 are measured at the bottom 0.3mm up inside the cavity, and K0 is the internal depth.
- (6) Chamfer R is 0.2-0.3 for cavity shape where it is not indicated
- (7) 5 ° if not indicated

Unless Otherwise specified tolerance
 X. ±0.35 X.XX: ±0.20
 X.X: ±0.25 X.XXX: ±0.15

Atkconn® ATKCONN ELECTRONICS CO., LTD
[Http://www.atkconn.com](http://www.atkconn.com)

SCALE: As Shown	UNIT: mm
DRAW ZLA	DATE 21/07/2022
CHECK BobYang	DATE 21/07/2022

TITLE:
Coin Cell Holders SMT For 1225C Tape And Reel

DRAWING NO: BS-M-SN-X-1225C
 PRODUCT NO: BS-M-SN-X-1225C

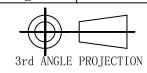

REV	DESCRIPTION	DATE
1		
2		
3		
4		
5		